

# P-PAB-PSA Series

Peripheral pumps capable of developing high heads using lowpowered motors.

Some models are available in the PB versions (bronze body for sea water), PK versions (compatible with hot water up to 80°C) and PBK versions (pump body in bronze compatible with hot water up to 80°C).

## Specifications

Delivery: up to 3.72 m<sup>3</sup>/h

Head: up to 82 m

Power supply: three-phase and single-phase 50 and 60 Hz

Power: 0.3 kW to 1.1 kW

Maximum operating pressure: 8 bar (10 bar for the PSA series)

Temperature of pumped liquid:

-10°C to +40°C (P series)

-10°C to +80°C (PSA-PAB-PABLB series)

Maximum ambient temperature: 40°C

Insulation class: F

Protection: IP44 (models P16, P21, PAB, PABLB)

IP55 (models P30, P40, P60, P70 e PSA)

## Materials

Pump body: Cast iron (P-PSA series)

Bronze (PB-PAB-PABLB series)

Adapter: Cast iron (P-PSA series)

Bronze (PB-PAB-PABLB series)

Impeller: Bronze

Mechanical seal: Ceramic/Carbon/NBR

Fill plugs: Brass

Elastomers: NBR

## Applications

Water distribution

Washing

Boiler

Hot water systems

Pressure boosting

Irrigation

Cooling and chilling



### По вопросам продаж и поддержки обращайтесь:

Архангельск (8182)63-90-72

Астана +7(7172)727-132

Астрахань (8512)99-46-04

Барнаул (3852)73-04-60

Белгород (4722)40-23-64

Брянск (4832)59-03-52

Владивосток (423)249-28-31

Волгоград (844)278-03-48

Вологда (8172)26-41-59

Воронеж (473)204-51-73

Екатеринбург (343)384-55-89

Иваново (4932)77-34-06

Ижевск (3412)26-03-58

Иркутск (395) 279-98-46

Казань (843)206-01-48

Калининград (4012)72-03-81

Калуга (4842)92-23-67

Кемерово (3842)65-04-62

Киров (8332)68-02-04

Краснодар (861)203-40-90

Красноярск (391)204-63-61

Курск (4712)77-13-04

Липецк (4742)52-20-81

Магнитогорск (3519)55-03-13

Москва (495)268-04-70

Мурманск (8152)59-64-93

Набережные Челны (8552)20-53-41

Нижегород (831)429-08-12

Новокузнецк (3843)20-46-81

Новосибирск (383)227-86-73

Омск (3812)21-46-40

Орел (4862)44-53-42

Оренбург (3532)37-68-04

Пенза (8412)22-31-16

Пермь (342)205-81-47

Ростов-на-Дону (863)308-18-15

Рязань (4912)46-61-64

Самара (846)206-03-16

Санкт-Петербург (812)309-46-40

Саратов (845)249-38-78

Севастополь (8692)22-31-93

Симферополь (3652)67-13-56

Смоленск (4812)29-41-54

Сочи (862)225-72-31

Ставрополь (8652)20-65-13

Сургут (3462)77-98-35

Тверь (4822)63-31-35

Томск (3822)98-41-53

Тула (4872)74-02-29

Тюмень (3452)66-21-18

Ульяновск (8422)24-23-59

Уфа (347)229-48-12

Хабаровск (4212)92-98-04

Челябинск (351)202-03-61

Череповец (8202)49-02-64

Ярославль (4852)69-52-93

Киргизия (996)312-96-26-47

Казахстан (772)734-952-31

Таджикистан (992)427-82-92-69

# P SERIES

## Operating characteristics at 50 Hz

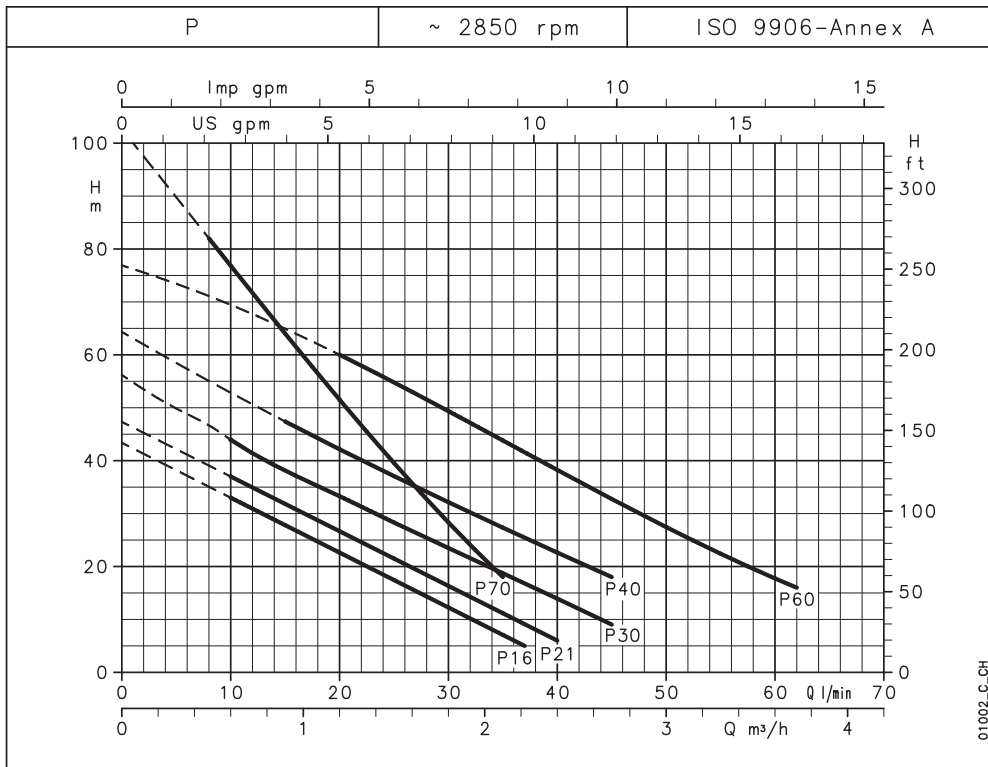

### Hydraulic performance table

PUMP TYPE	RATED POWER		Q = DELIVERY										
			l/min	0	8	10	15	20	35	37	40	45	62
	kW	HP	m³/h	0	0,48	0,60	0,90	1,20	2,10	2,22	2,40	2,70	3,72
H = TOTAL HEAD IN COLUMN OF WATER (METRES)													
P(M)16	0,3	0,4		43,4		33,0	27,8	22,6	7,1	5,0			
P(M)21	0,37	0,5		47,4		37,0	31,8	26,7	11,2	9,1	6,0		
P(M)30	0,5	0,7		56,2		44,0	38,5	33,3	18,7	16,8	13,9	9,0	
P(M)40	0,6	0,8		64,3			47,4	42,2	27,3	25,4	22,6	18,0	
P(M)60	1,1	1,5		76,9				60,0	43,8	41,6	38,2	32,8	16,0
P(M)70	0,75	1		102,6	82,0	76,8	64,0	51,5	18,0				

These performances are valid for liquids with density  $\rho = 1.0 \text{ kg/dm}^3$  and kinematic viscosity  $\nu = 1 \text{ mm}^2/\text{s}$ .

p-2p50\_b\_th

### Electrical data

PUMP TYPE	MOTOR TYPE	INPUT POWER*	INPUT CURRENT* 220-240 V	CAPACITOR $\mu\text{F} / 450 \text{ V}$	PUMP TYPE	MOTOR TYPE	INPUT POWER*	INPUT CURRENT* 220-240 V	INPUT CURRENT* 380-415 V
1 ~		kW	A		3 ~		kW	A	A
PM16	30M712	0,50	2,2	10	P16	30T712	0,48	1,55	0,9
PM21	37M712	0,58	2,7	14	P21	37T712	0,55	1,9	1,1
PM30	SM71PA/105	0,83	4	16	P30	SM71PA/305	0,72	2,6	1,5
PM40	SM71PA/107	1,08	4,82	20	P40	SM80PA/307HE	1,00	3,15	1,82
PM60	SM80PA/111	1,77	7,95	30	P60	SM80PA/311HE	1,68	4,95	2,86
PM70	SM71PA/109	1,32	5,89	25	P70	SM80PA/311HE	1,24	3,86	2,23

\*Maximum value in specified range.

p-2p50-en\_c\_te

# PAB SERIES

## Operating characteristics at 50 Hz

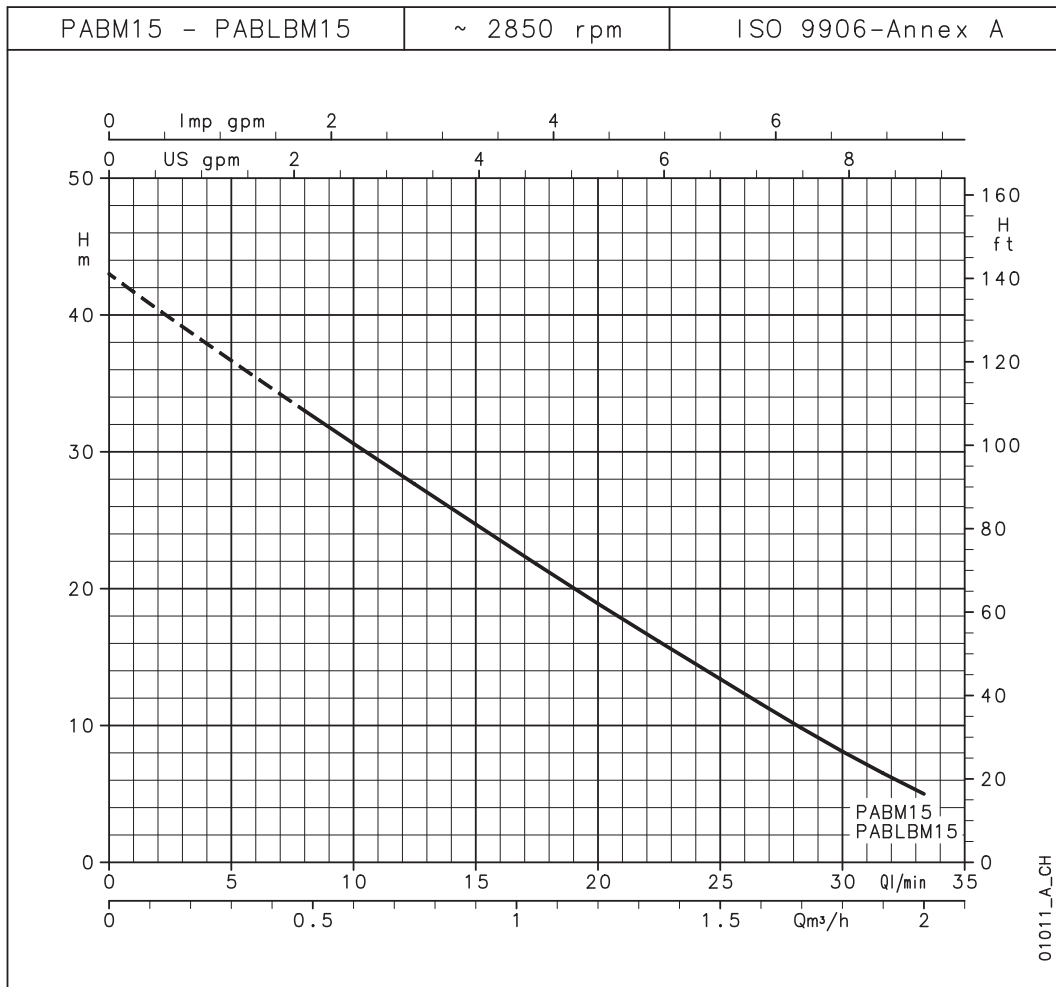

### Hydraulic performance table

PUMP TYPE	RATED POWER		Q = DELIVERY							
			l/min	8	10	15	20	25	30	33
			0	0,48	0,60	0,90	1,20	1,50	1,80	1,98
			m <sup>3</sup> /h	0	0,60	0,90	1,20	1,50	1,80	1,98
			H = TOTAL HEAD IN COLUMN OF WATER (METRES)							
PABM15	0,37	0,5	43,0	33,0	30,6	24,7	18,9	13,4	8,1	5,0
PABLBM15	0,37	0,5	43,0	33,0	30,6	24,7	18,9	13,4	8,1	5,0

These performances are valid for liquids with density  $\rho = 1.0 \text{ kg/dm}^3$  and kinematic viscosity  $\nu = 1 \text{ mm}^2/\text{s}$ .

pab-2p50\_a\_th

### Electrical data

PUMP TYPE	INPUT POWER*		CAPACITOR	PUMP TYPE	INPUT POWER*		INPUT CURRENT*
	SINGLE-PHASE				THREE-PHASE		
PABM15	0,47	2,1	10	-	-	-	-
PABLBM15	0,47	2,1	10	-	-	-	-

\*Maximum value in specified value

pab-2p50\_a\_te

# PSA70 SERIES

## Operating characteristics at 50 Hz

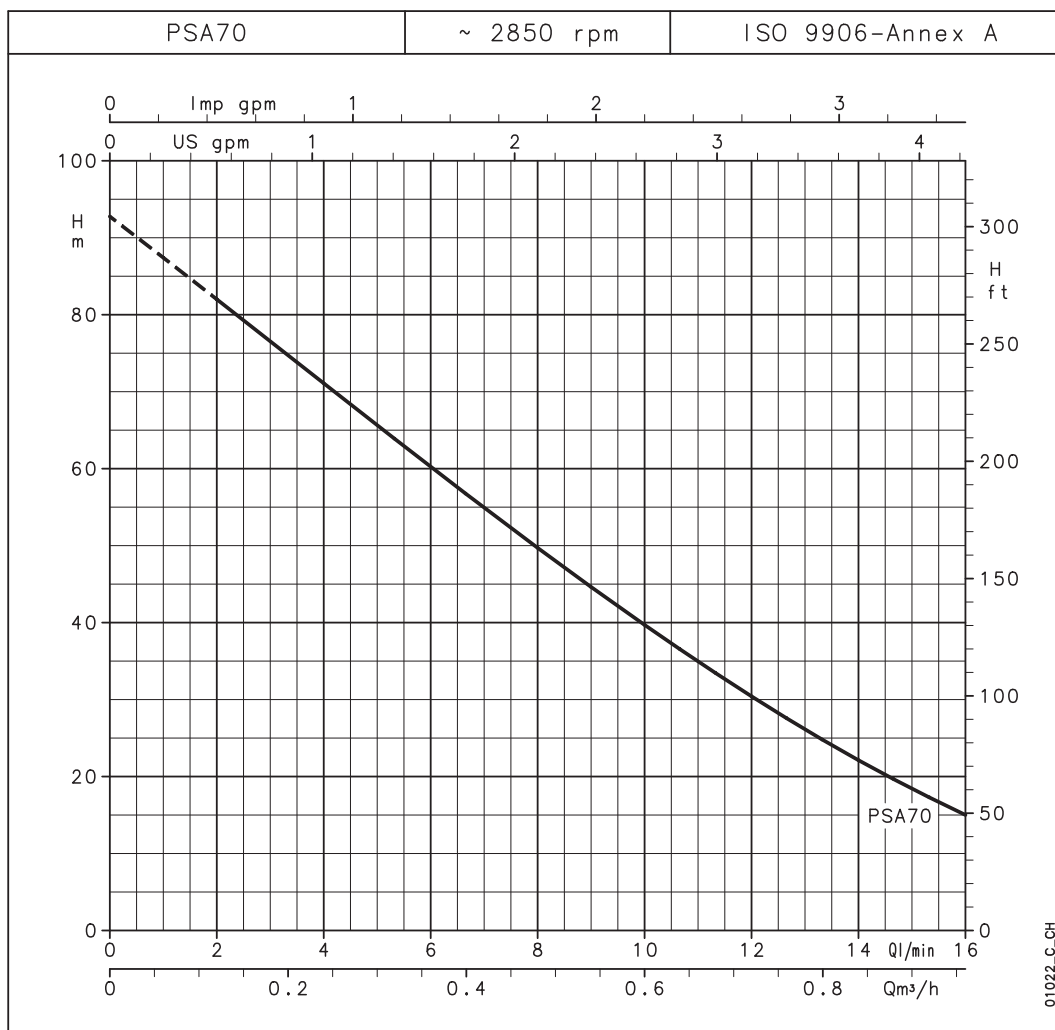

### Hydraulic performance table

PUMP TYPE	RATED POWER		Q = DELIVERY							
			l/min	2	4	8	10	12	14	16
			0	0,12	0,24	0,48	0,6	0,72	0,84	0,96
			H = TOTAL HEAD IN COLUMN OF WATER (METRES)							
PSA(M)70	0,37	0,5	92,8	82,0	71,1	49,7	39,7	30,4	22,1	15,0

These performances are valid for liquids with density  $\rho = 1.0 \text{ kg/dm}^3$  and kinematic viscosity  $\nu = 1 \text{ mm}^2/\text{s}$ .

psa-2p50\_a\_th

### Electrical data

PUMP TYPE	INPUT POWER*	INPUT CURRENT*	CAPACITOR	PUMP TYPE	INPUT POWER*	INPUT CURRENT*	INPUT CURRENT*
SINGLE-PHASE		220-240 V		THREE-PHASE		220-240 V	380-415 V
	kW	A	$\mu\text{F} / 450 \text{ V}$		kW	A	A
PSAM70	0,75	3,41	16	PSA70	0,76	2,75	1,59

\*Maximum value in specified range

psa-2p50\_a\_te

# 1 P SERIES Dimensions and weights

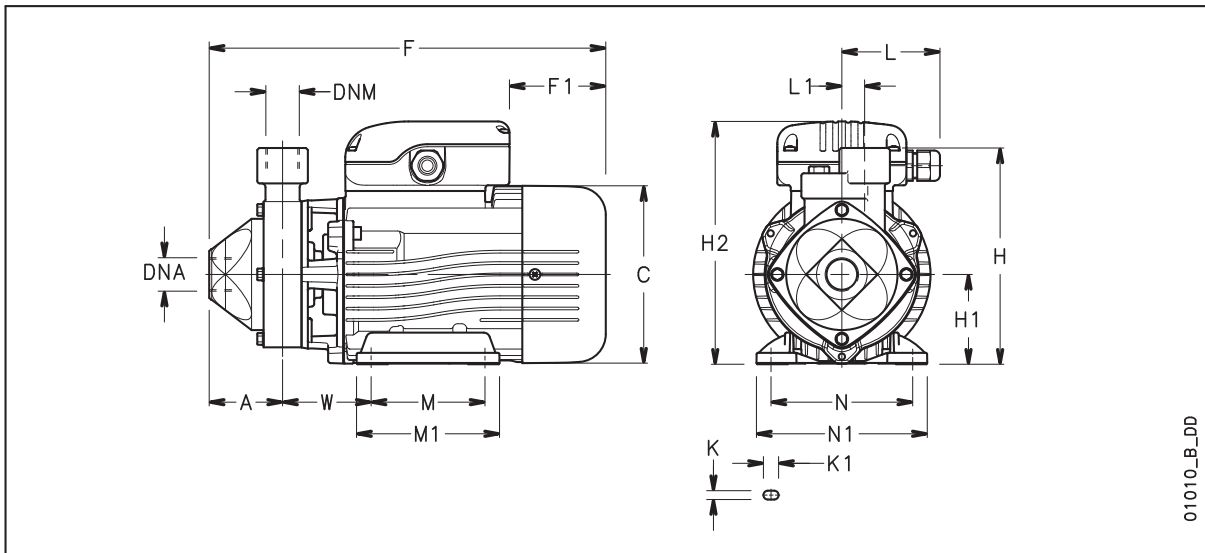
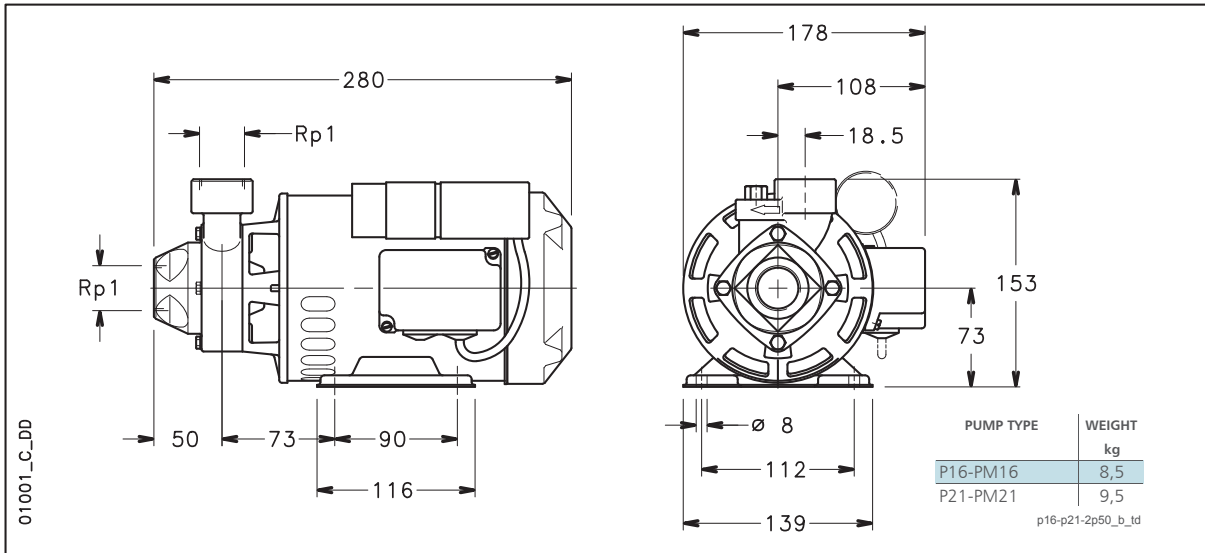

PUMP TYPE	DIMENSIONS (mm)																DNA DNM	WEIGHT kg
	A	C	F	F1	H	H1	H2	L	L1	M	M1	N	N1	K	K1	W		
PM30	55	140	311	76	161	71	192	78	20	90	113	112	135	7	12	70,5	Rp 1	9,7
PM40	55	140	311	76	161	71	192	78	20	90	113	112	135	7	12	71	Rp 1	10,2
PM60	58	155	354	68	180	80	217	81	20	100	124	125	153	9	12	83	Rp 1	15,5
PM70	58	140	314	76	171	71	192	78	18	90	113	112	135	7	12	70	Rp 3/4	11,5
P30	55	140	311	76	161	71	192	78	20	90	113	112	135	7	12	70,5	Rp 1	9,7
P40	55	155	350	113	170	80	209	78	20	100	124	125	153	9	12	83	Rp 1	13,5
P60	58	155	354	113	180	80	209	78	20	100	124	125	153	9	12	83	Rp 1	17
P70	58	155	353	113	180	80	209	78	18	100	124	125	153	9	12	82	Rp 3/4	14,8

p30-70-2p50-en\_c\_td

# PAB-PSA70 SERIES

## Dimensions and weights

